

METAL
BAR
GRATING

AMERICAN NATIONAL STANDARD

ANSI/NAAMM
STANDARD

MBG 533-09

GRATINGS



ANSI/NAAMM — MBG 533-09
June 15, 2009

WELDING STANDARDS
FOR FABRICATION OF
STEEL, STAINLESS STEEL
AND ALUMINUM
BAR GRATING

THIRD EDITION

ANSI/NAAMM — MBG 533-09

June 15, 2009



GRATINGS

MBG Metal Bar Grating

A Division of

NAAMM

NATIONAL ASSOCIATION OF
ARCHITECTURAL METAL MANUFACTURERS

Approval of an American National Standard requires verification by ANSI that the requirements for due process, consensus, and other criteria for approval have been met by the standards developer.

Consensus is established when, in the judgment of the ANSI Board of Standards Review, substantial agreement has been reached by directly and materially affected interests. Substantial agreement means much more than a simple majority, but not necessarily unanimity. Consensus requires that all views and objections be considered, and that a concerted effort be made toward their resolution.

The use of American National Standards is completely voluntary, their existence does not in any respect preclude anyone, whether he has approved the standards or not, from manufacturing, marketing, purchasing, or using products, processes, or procedures not conforming to the standards.

The American National Standards Institute does not develop standards and will in no circumstances give an interpretation of any American National Standard. Moreover, no person shall have the right or authority to issue an interpretation of an American National Standard in the name of the American National Standards Institute. Requests for interpretation should be addressed to the sponsor whose name appears on the title page of this standard.

CAUTION NOTICE: This American National Standard may be revised or withdrawn at any time. The procedures of the American National Standards Institute require that action be taken periodically to reaffirm, revise, or withdraw this standard. Purchasers of American National Standards may receive current information on all standards by calling or writing the American National Standards Institute.

This standard was developed by representative members of the Metal Bar Grating Division (MBG) of the National Association of Architectural Metal Manufacturers (NAAMM) to provide their opinion and guidance on the welding of metal bar gratings. This standard contains advisory information only and is published as a public service by NAAMM. NAAMM and its Divisions disclaim all liability of any kind for the use, application, or adaptation of material published in this standard.

Current information on all NAAMM Standards is available by calling or writing the National Association of Architectural Metal Manufacturers or by going to www.naamm.org.

National Association of Architectural Metal Manufacturers

800 Roosevelt Road

Bldg. C, Suite 312

Glen Ellyn, Illinois 60137

Phone: (630) 942-6591 Fax: (630) 790-3095

www.naamm.org

Copyright © 1979, 1989, 2009

National Association of Architectural Metal Manufacturers

All Rights Reserved

WELDING STANDARDS

For Fabrication of Steel, Stainless Steel and Aluminum Bar Grating

Third Edition

ANSI/NAAMM MBG 533-09

Published and distributed by the

NATIONAL ASSOCIATION OF ARCHITECTURAL METAL MANUFACTURERS

800 Roosevelt Road
Bldg. C, Suite 312
Glen Ellyn, Illinois 60137
Phone: (630) 942-6591
email: info@naamm.org

NAAMM MBG 533.09
WELDING STANDARD FOR FABRICATION
OF
STEEL, STAINLESS STEEL AND ALUMINUM BAR GRATING

SECTION 1

GENERAL PROVISIONS

1.1 APPLICATIONS

This Standard covers fillet welding requirements as they apply to bar grating made of steel, aluminum and stainless steel. The provisions cover banding, toe plates, treads, and miscellaneous material. (See welding standards in NAAMM Metal Bar Grating Manual, ANSI/NAAMM MBG 531 and NAAMM Heavy Duty Metal Bar Grating Manual, ANSI/NAAMM MBG 532, latest editions.) The provisions are not intended to cover high stress structural welds. If conditions should require such welding the applicable provisions of the American Welding Society Structural Welding Codes, AWS-D1.1 for carbon and low alloy steel, except for Section 3.10, and AWS-D1.2 for aluminum and AWS-D1.6 for stainless steel (latest editions to be applied).

1.2 BASE METAL

1.2.1 Metals to be welded under this Standard shall conform with the requirements of the latest edition of one of the following specifications. Combinations of these steel base metals may be welded together.

1.2.1.1 ASTM A 36 / A 36M Specification for Carbon Structural Steel. (For bars only)

1.2.1.2 ASTM A 510 (ASTM A 510M) Specification for General Requirements for Wire Rods and Coarse Round Wire, Carbon Steel.

1.2.1.3 ASTM A 606 Specification for Steel, Sheet and Strip, High Strength, Low Alloy, Hot-Rolled and Cold-Rolled with Improved Atmospheric Corrosion Resistance.

1.2.1.4 ASTM A 666 Specification for Annealed or Cold-Worked Austenitic Stainless Steel Sheet, Strip, Plate and Flat Bar. Type 304, 304L, 316 or 316L Alloy.

1.2.1.5 ASTM A 1011 / A 1011 M Standard Specification for Steel, Sheet and Strip, Hot-Rolled, Carbon, Structural, High-Strength Low Alloy, High-Strength Low-Alloy with Improved Formability, and Ultra-High Strength. CS Type B, SS Grade 36.

1.2.1.6 ASTM A 1018 / A 1018 M Standard Specification for Steel, Sheet and Strip, Heavy-Thickness Coils, Hot-Rolled, Carbon, Commercial, Drawing, Structural, High-Strength Low Alloy, High-Strength Low-Alloy with Improved Formability, and Ultra-High Strength Steel. SS Grade 36.

1.2.1.7 ASTM B 221 (ASTM B 221M) Specification for Aluminum and Aluminum-Alloy Extruded Bars, Rods, Wire, Profiles, and Tubes. Alloys 6061-T6 and 6063-T6.

1.2.2 When metals other than those listed in 1.2.1 are specified, the weldability of the metal and the procedure for welding it shall be established by the customer.

1.3 WELDING PROCESS

Manual shielded metal-arc (SMAW) and gas metal-arc welding (GMAW) procedures are considered prequalified and approved for use without performing procedure qualification tests.

1.4 DEFINITIONS

The welding terms used in this Standard shall be interpreted in accordance with the definitions given in the latest edition of Terms and Definitions (AWS A3.0) of the American Welding Society.

1.5 WELDING SYMBOLS

Welding symbols shall be those shown in the latest edition of Standard Welding Symbols (AWS A2.4) of the American Welding Society. Special welding conditions shall be fully explained by added notes or details on drawings.

1.6 SAFETY PRECAUTIONS

Safety precautions shall conform to the latest edition of ANSI Z49.1, Safety in Welding, Cutting, and Allied Processes published by the American Welding Society. This code may not address all hazards with welding and should not be considered all inclusive.

SECTION 2.

DESIGN OF WELDED CONNECTIONS

2.1 WELDING STANDARDS

Figures 2.1.1, 2.1.2, 2.1.3, 2.1.4, 2.1.5, 2.1.6, 2.1.7, and 2.1.8 cover welding standards for bar gratings. These standards apply to steel, aluminum and stainless steel gratings and treads and to steel gratings galvanized as per specifications set forth in ANSI/NAAMM MBG 531 or ANSI/NAAMM MBG 532.

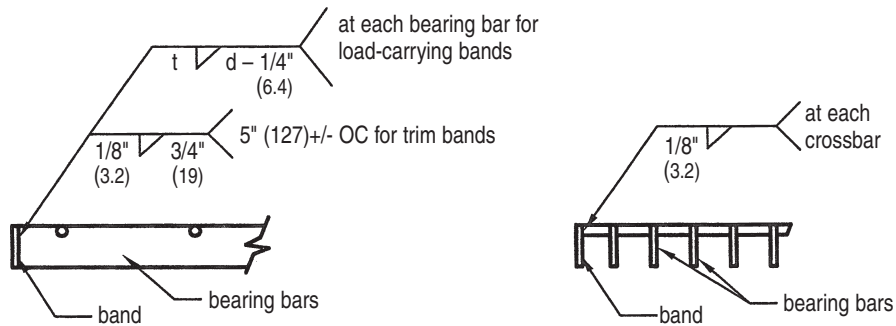

BANDING FOR STANDARD GRATING

Figure 2.11

(bearing bar thickness less than 1/4" (6mm) and bearing bar clear opening greater than or equal to 5/8" (16mm))

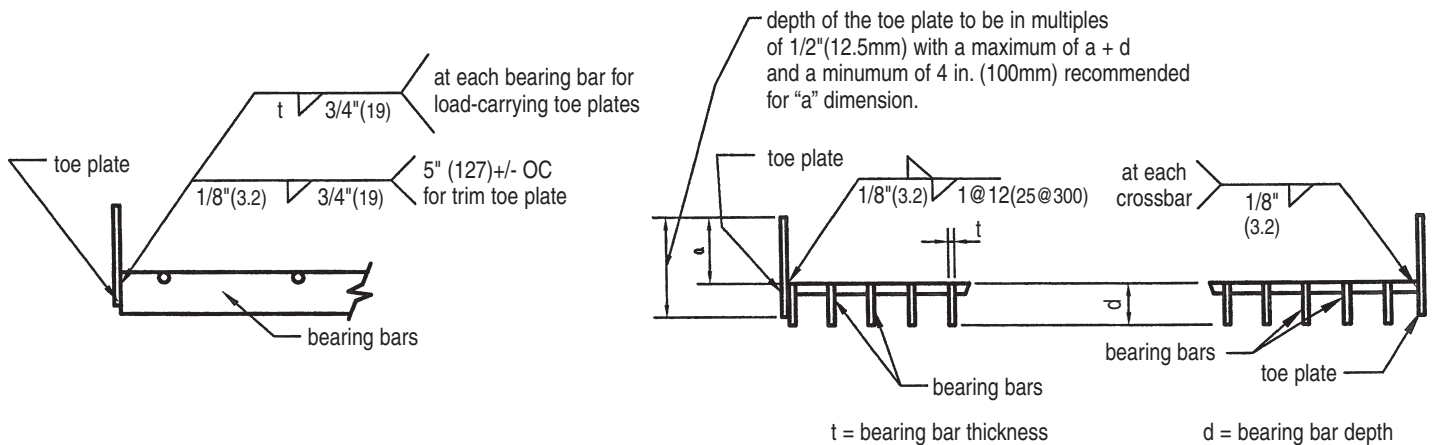

TOE PLATE FOR STANDARD GRATING

Figure 2.12

(bearing bar thickness less than 1/4" (6mm) and bearing bar clear opening greater than or equal to 5/8" (16mm))

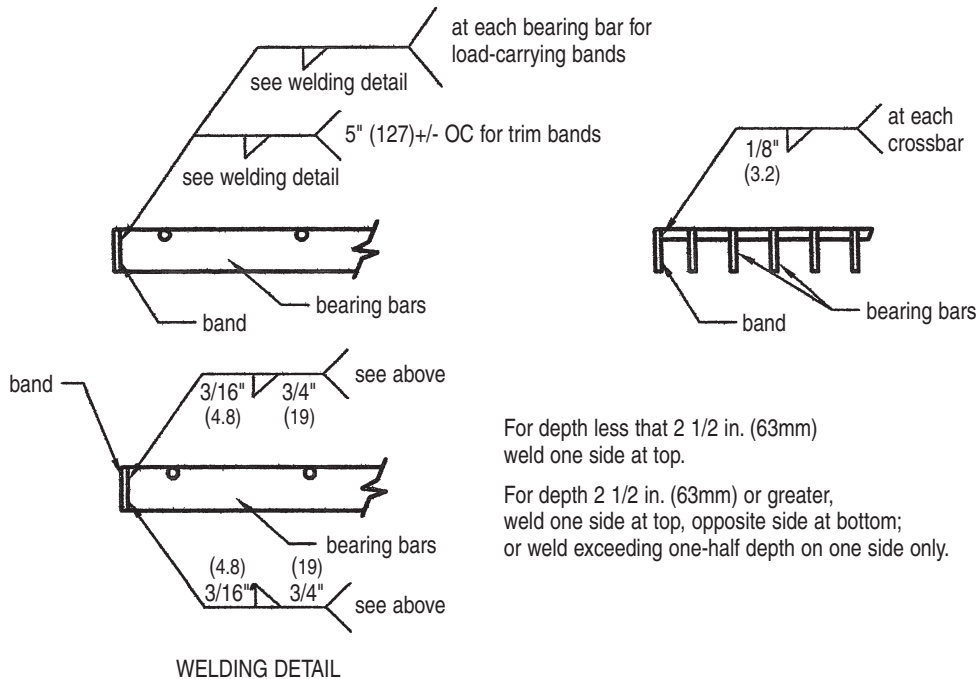

For depth less than 2 1/2 in. (63mm)
weld one side at top.

For depth 2 1/2 in. (63mm) or greater,
weld one side at top, opposite side at bottom;
or weld exceeding one-half depth on one side only.

BANDING FOR HEAVY DUTY GRATING

Figure 2.13

(bearing bar thickness 1/4"(6mm) and greater and bearing bar clear opening greater than or equal to 5/8" (16mm))

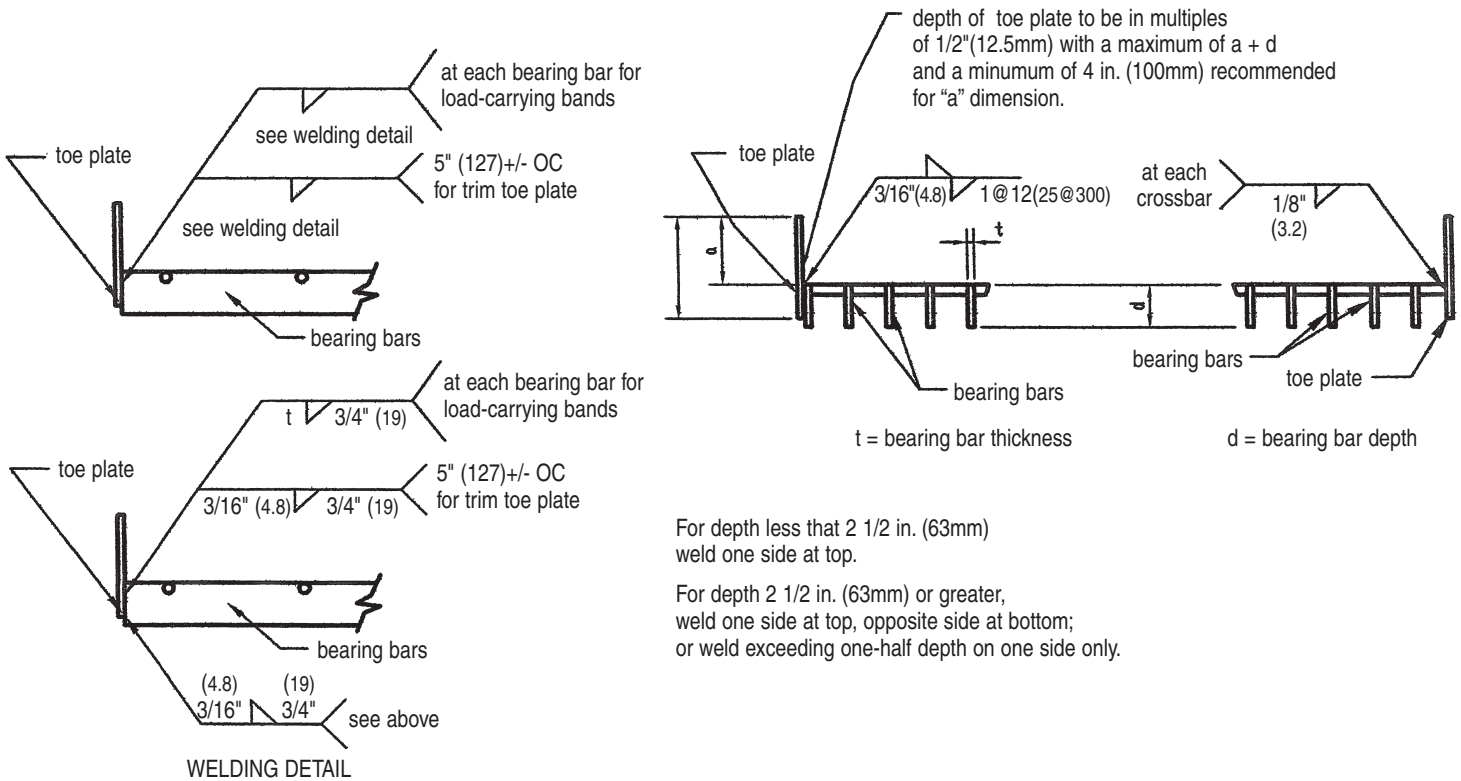

For depth less than 2 1/2 in. (63mm)
weld one side at top.

For depth 2 1/2 in. (63mm) or greater,
weld one side at top, opposite side at bottom;
or weld exceeding one-half depth on one side only.

TOE PLATE FOR HEAVY DUTY GRATING

Figure 2.14

(bearing bar thickness 1/4"(6mm) and greater and bearing bar clear opening greater than or equal to 5/8" (16mm))

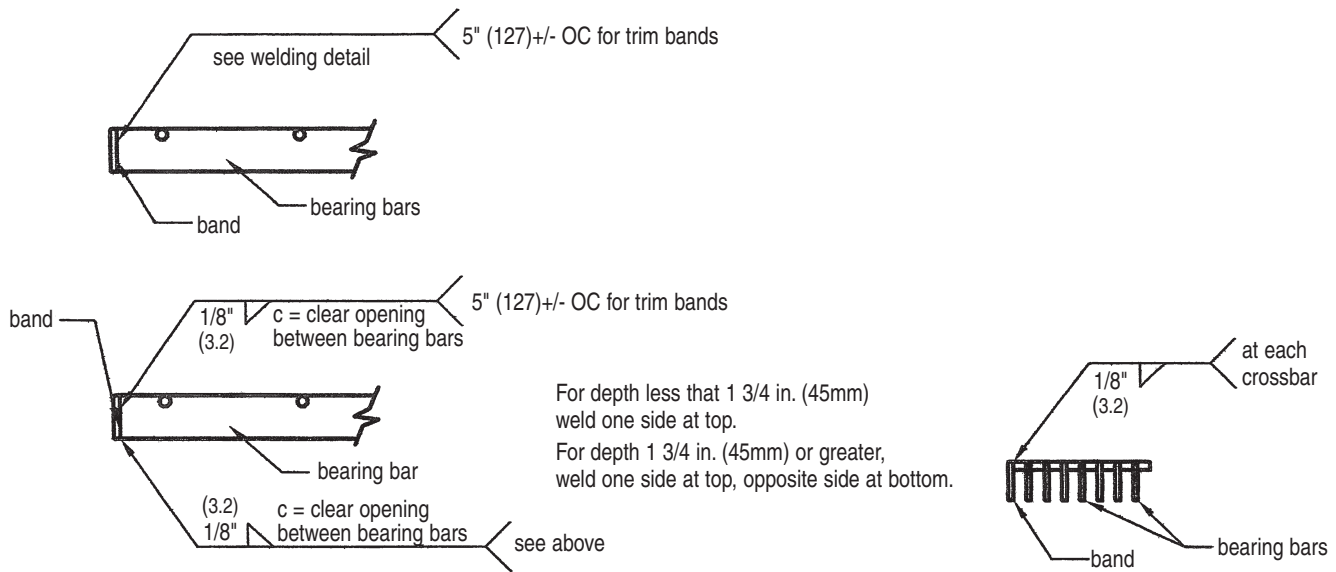

WELDING DETAIL

Note for aesthetic applications specify weld placement,

BANDING FOR CLOSE-MESH GRATING Figure 2.15

(all grating and treads with bearing bars having a clear opening less than 5/8" (16mm))

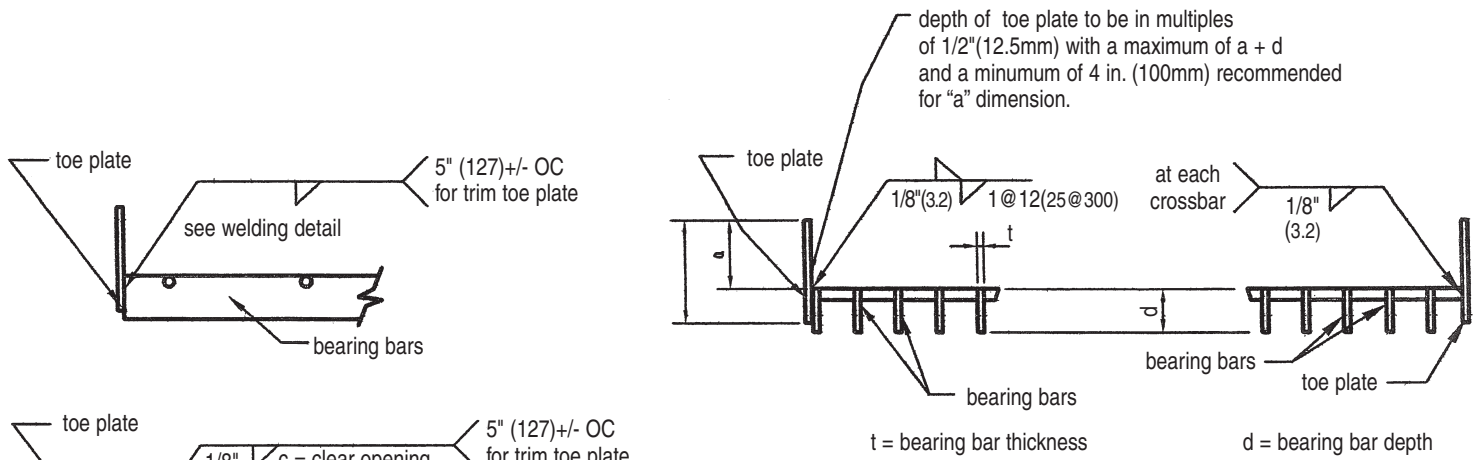

WELDING DETAIL

TOE PLATE FOR HEAVY DUTY GRATING Figure 2.16

(all grating with bearing bars having a clear opening less than 5/8" (16mm))

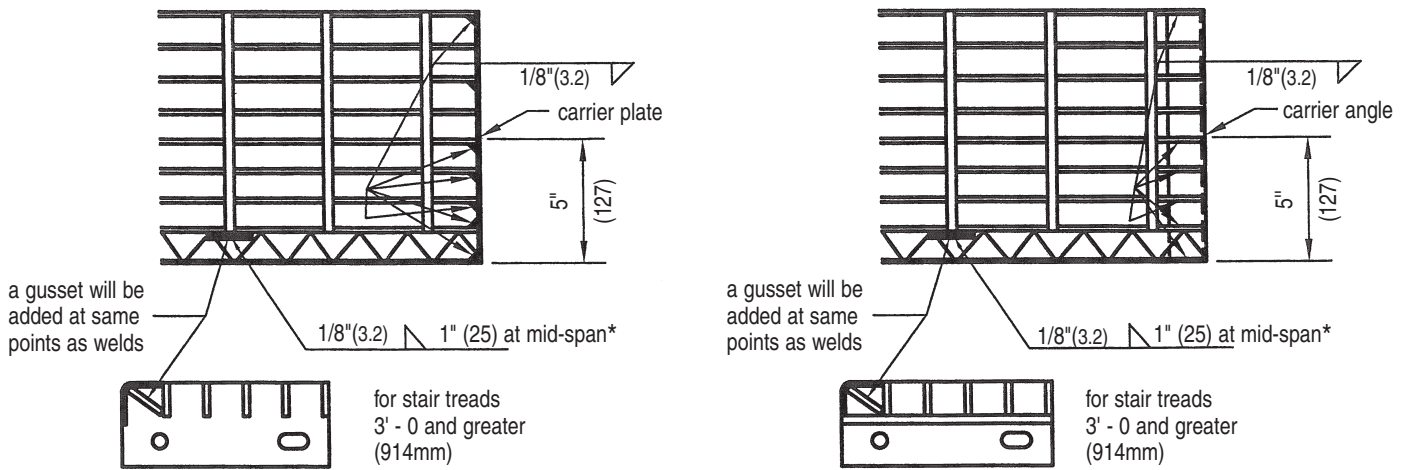

when carrier plates and carrier angles are used, the bearing bars in the front five inches, the back bearing bar, and the nosing shall be welded to the carrier plate or carrier angle as shown.

On treads over 9-3/4 in. (248) wide weld end of center bar also.
 * Treads spanning 4 ft. (1.2m) or more shall have welds and gussets located at the third points.

STANDARD STAIR TREADS Figure 2.17
 (bearing bar thickness less than 1/4"(6mm) and bearing bar clear opening greater than or equal to 5/8" (16mm))

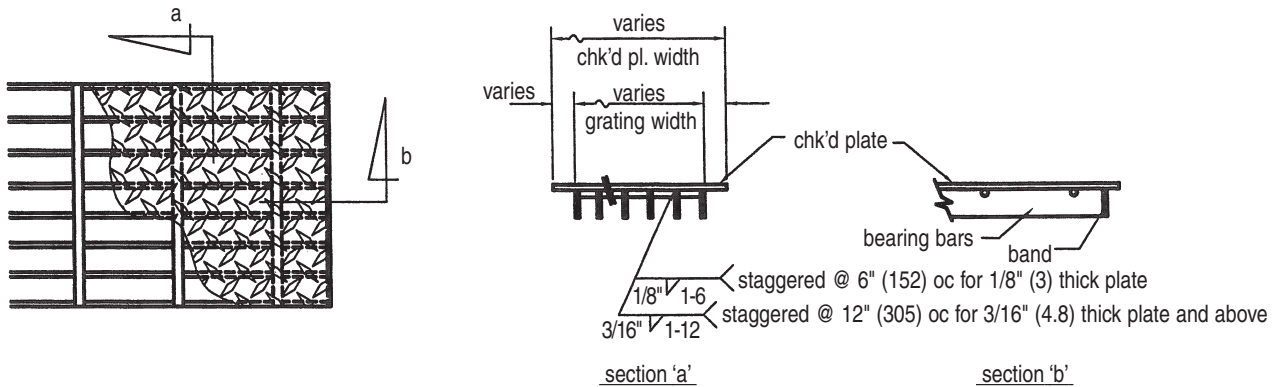

STANDARD PLATE ATTACHMENT TO GRATING Figure 2.18

2.2 DRAWINGS

When there are no special requirements by the customer, the Welding Standards covered by 2.1 shall apply and no additional information need be shown on the drawings. For other than standards the drawings shall show full and complete information regarding location, type, size, and extent of all welds.

SECTION 3

WORKMANSHIP

3.1 GENERAL

- 3.1.1 All pertinent paragraphs of this section shall apply in the production and inspection of welded assemblies produced by any of the processes acceptable under this Standard.
- 3.1.2 All items of equipment for welding and oxygen cutting shall be so designed and manufactured, and be in such condition, as to enable qualified welders and tackers to follow the procedures and attain the results prescribed in this Standard.
- 3.1.3 No welding shall be done when the ambient temperature is lower than 0°F (-17.8°C), when surfaces are wet or exposed to rain, snow, wind in excess of 5 mph (GMAW only) or when welders are exposed to inclement conditions without proper shelter.
- 3.1.4 The sizes and lengths of welds shall not be less than those specified in 2.1 or as shown on detail drawings. The location of welds shall not be changed without approval of the customer.

3.2 PREPARATION OF BASE METAL

- 3.2.1 Surfaces of steel to be welded and surfaces adjacent to the weld shall be free of loose or thick scale, slag, rust, moisture, grease, or other foreign material that will prevent proper welding. Mill scale that withstands vigorous wire brushing, a thin rust inhibitive coating, or anti-spatter compound need not be removed.
- 3.2.2 Surfaces of aluminum and stainless steel to be welded and surfaces adjacent to the weld shall be free of moisture, grease or other foreign material that will prevent proper welding.
- 3.2.3 In all oxygen cutting, the cutting flame shall be so adjusted and manipulated as to avoid cutting beyond (inside) the prescribed lines. Roughness of oxygen cut surfaces shall not be greater than that defined by ANSI/ASME B46.1 as having a surface roughness value of 2000 micro in. Roughness exceeding this value and occasional notches or gouges shall be removed by grinding. Cut surfaces and edges shall be left free of cutting dross or slag that will have an adverse affect on the weld.

3.3 ASSEMBLY

- 3.3.1 The parts to be joined shall be brought into as close contact as practicable
- 3.3.1.1 For galvanized parts refer to ASTM A 385 Practice for Providing High-Quality Zinc Coatings (Hot Dip)

3.3.2 TACK WELDS

- 3.3.2.1 Tack welds shall be subject to the same requirements as the final welds except that preheat is not mandatory for single pass tack welds which are remelted and incorporated into the final welds.
- 3.3.2.2 Tack welds which are to be incorporated into the final welds shall be made with electrodes meeting the requirements of the final weld.
- 3.3.2.3 Tack welds not incorporated into final welds need not be removed, but shall be made with electrodes meeting the requirements of the final weld.

3.4 CONTROL OF DISTORTION AND SHRINKAGE

- 3.4.1 In assembling parts the procedure and sequence shall be such as will minimize distortion and shrinkage.
- 3.4.2 Insofar as practicable, all welds shall be deposited in a sequence that will balance the applied heat of welding while the welding progresses.
- 3.4.3 The welding sequences used shall be such as will produce assemblies meeting the quality requirements specified.

3.5 DIMENSIONAL TOLERANCES

The dimensions of the final welded assembly shall be within the manufacturing tolerances established in ANSI/NAAMM MBG 531 or ANSI/NAAMM MBG 532.

3.6 WELD PROFILES

The faces of the fillet welds may be slightly convex, flat, or slightly concave as shown in Fig. 3.6, Details A, B, and C. Except at outside corner joints, the convexity shall not exceed that shown in Fig. 3.6, Detail C.

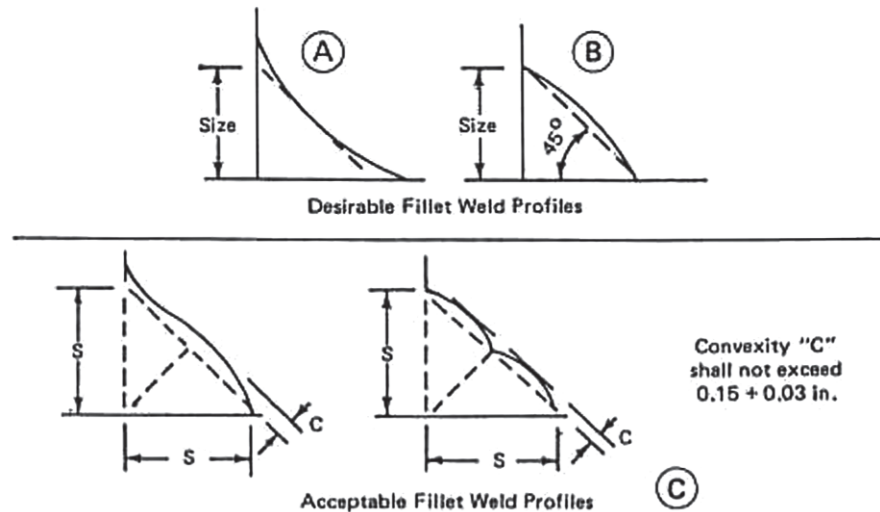

Fig. 3.6—Illustrations of acceptable weld profiles

3.7 CORRECTIONS

- 3.7.1 Remove excess weld metal by grinding, chipping, or air carbon arc cutting in such a manner that the remaining weld metal or base metal is not damaged. Surfaces shall be cleaned before rewelding.
- 3.7.2 Defective or unsound welds or base metal shall be corrected as follows:
- 3.7.2.1 Overlap or excessive convexity: Reduce by removal of excess weld metal.
- 3.7.2.2 Unacceptable concavity of weld or crater, undersize weld, undercutting: Clean and deposit additional weld metal.
- 3.7.2.3 Unacceptable weld porosity, excessive slag inclusions, incomplete fusion: Remove defective portions and reweld.
- 3.7.3 Members distorted by welding shall be straightened by mechanical means or, in the case of steel or stainless steel, by localized heating to a temperature not exceeding 1200°F (649°C) (dull red). Localized heating shall not be used on aluminum.

3.8 CLEANING

Slag shall be cleaned from all welds.

SECTION 4

TECHNIQUE

4.1 FILLER METAL REQUIREMENTS

- 4.1.1 The electrodes for carbon and low alloy steel shall meet the following specifications:
- AWS A5.1** Carbon Steel Electrodes for SMAW.
 - AWS A5.5** Low-Alloy Steel Electrodes for SMAW.

- 4.1.2** The electrodes for carbon steel shall meet the following specifications:
AWS A5.18 Carbon Steel Electrodes and ROD5 for Gas Shielded Arc Welding
AWS A5.20 Carbon Steel Electrodes for Flux Cored Arc Welding
- 4.1.3** The electrodes for aluminum shall meet the following specifications:
AWS A5.3 Aluminum and Aluminum Alloy Covered Arc Welding Electrodes
AWS A5.10 Aluminum and Aluminum Alloy Bare Welding Rods and Electrodes
- 4.1.4** The electrodes for stainless steel shall meet the following specifications:
AWS A5.4 Covered Corrosion-Resisting Chromium and Chromium-Nickel Steel Welding Electrodes
AWS A5.9 Corrosion-Resisting Chromium and Chromium-Nickel Steel Bare and Composite Metal Cored and Stranded Welding Electrodes and Welding Rods
AWS A5.22 Flux Cored Corrosion-Resisting Chromium and Chromium-Nickel Steel Electrodes
- 4.1.5** For ASTM A 606 steel where corrosion resistance and coloring characteristics of the weld are to be similar to the base metal use the appropriate AWS A5.5 electrodes. When color match is not important but similar corrosion characteristics are required in the weld, use E70XX low-hydrogen electrodes.
- 4.1.6** After filler metal has been removed from its original package it shall be so protected or stored that its characteristics or welding properties are not adversely affected thus limiting intended performance.
- 4.2 SHIELDING GAS**
- 4.2.1** When a gas or gas mixture is used for shielding in gas metal arc welding, it shall be of a welding grade having a dew point of -40°F (-40°C) or lower.
- 4.2.2** Welding with external gas shielding shall not be done in a draft or wind having a velocity greater than 5 miles per hour. (8 km/h)
- 4.3 PREHEAT AND INTERPASS TEMPERATURE REQUIREMENTS**
- There is no requirement for preheat and interpass temperature unless the base metal is below 32°F (0°C). If temperature of base metal is below 32°F (0°C), it shall be preheated to at least 70°F (21.1°C) and shall be maintained at this minimum temperature during welding.
- 4.4 ARC STRIKES**
- Arc strikes outside the area of permanent welds should be avoided on any base metal. Cracks or blemishes resulting from arc strikes shall be ground.
- 4.5 WELD CLEANING**
- Before welding over previously deposited metal all slag shall be removed and the weld and adjacent metal shall be brushed clean.

SECTION 5

QUALIFICATION

PART I GENERAL REQUIREMENTS

5.1 APPROVED PROCEDURES

- 5.1.1** Welding procedures which conform to the provisions set forth in Sections 1, 2, 3 and 4 shall be deemed as prequalified and are exempt from tests or qualification.
- 5.1.2** All prequalified welding procedures shall be described by the grating fabricator in a written procedure specification which shall be available to those authorized to examine them.

5.2 OTHER PROCEDURES

Except for the procedures exempted in 5.1, welding procedures which are to be employed in executing contract work shall be previously qualified by tests as hereinafter prescribed when so requested by the customer's specification. The customer shall accept properly documented evidence of previous qualification.

5.3 WELDERS, WELDING OPERATORS AND TACKERS

All welders, welding operators and tackers to be employed under this Standard shall have been qualified as prescribed in Parts II, III, and IV of Section 5. The customer shall accept properly documented evidence of previous qualification.

5.4 QUALIFICATION RESPONSIBILITY

Each grating fabricator shall conduct such tests as are required by this Standard to qualify the welding procedures and the welders, welding operators and tackers who will apply the procedures.

PART II PROCEDURE QUALIFICATION

5.5 LIMITATION OF VARIABLES

5.5.1 When necessary to establish a welding procedure by qualification as required by 5.2 or contract specification the following rules apply and the procedure shall be recorded by the grating fabricator as a procedure specification.

5.5.1.1 Qualification of a welding procedure established with base metals of steel or stainless steel having a minimum specified yield point of 50,000 psi (344.7 MPa) shall qualify that procedure for any other base metals of steel or stainless steel (or combination of metals) having a specified yield point equal to or less than 50,000 psi (344.7 MPa). The applicable version and section of AWS D1.2 (for aluminum) shall be referred and followed for the selection of base metal.

5.5.2 The changes set forth in the following schedule shall be considered essential changes in a welding procedure and shall require establishing a new procedure by qualification.

5.5.2.1 SHIELDED METAL-ARC WELDING

- (1) A change increasing filler metal strength level; e.g., for base metal of steel, a change from E70XX to E80XX, but not vice versa.
- (2) A change from a low-hydrogen type electrode to a non-low-hydrogen type of electrode, but not vice versa.
- (3) An Increase in diameter of the electrode used, over that called for in the procedure specification.
- (4) A change of more than 15% above or below the specified mean arc voltage and amperage for each size electrode used.
- (5) A change in position in which welding is done.
- (6) A decrease of more than 25°F (13.9°C) in the minimum specified preheat temperature.
- (7) In the case of vertical welding, a change from the progression specified for any pass from upward to downward or vice versa.

5.5.2.2 GAS-METAL ARC WELDING

- (1) A change in electrode and method of shielding not covered by AWS specification A5.9, A5.10 and A5.18.
- (2) A change increasing filler metal strength level; e.g., for a base metal of steel, grade E70S to grade E80S, but not vice versa.
- (3) A change in electrode diameter.
- (4) A change from a single gas to any other single gas or to a mixture of gases, or a change in specified percentage composition of gas mixture not covered by AWS A5.9, A5.10 and A5.18.

- (5) A change of more than 10% above or below the specified mean amperage for each size electrode used.
- (6) A change of more than 7 % above or below the specified mean arc voltage for each size electrode used.
- (7) A change of more than 10% above or below the specified mean travel speed.
- (8) An increase of 25% or more or a decrease of 10% or more in the rate of flow of shielding gas or mixture.
- (9) A change in position in which welding is done.
- (10) A decrease of more than 25% in the minimum specified preheat temperature.
- (11) In the case of vertical welding a change from the progression specified for any pass from upward to downward or vice versa.
- (12) A change in type of welding current (ac or dc), polarity or mode of metal transfer across arc.

5.6 TYPES OF TESTS

Fillet welds shall be subject to visual tests for soundness and quality.

5.7 BASE METAL AND ITS PREPARATION

The base metal and its preparation for welding shall comply with the procedure specification.

5.8 POSITION OF TEST WELDS

All welds encountered in grating fabrication are horizontal or vertical. Each procedure shall be tested for each position for which it is to be qualified. Test plates shall be welded in the position outlined in Fig. 5.8.

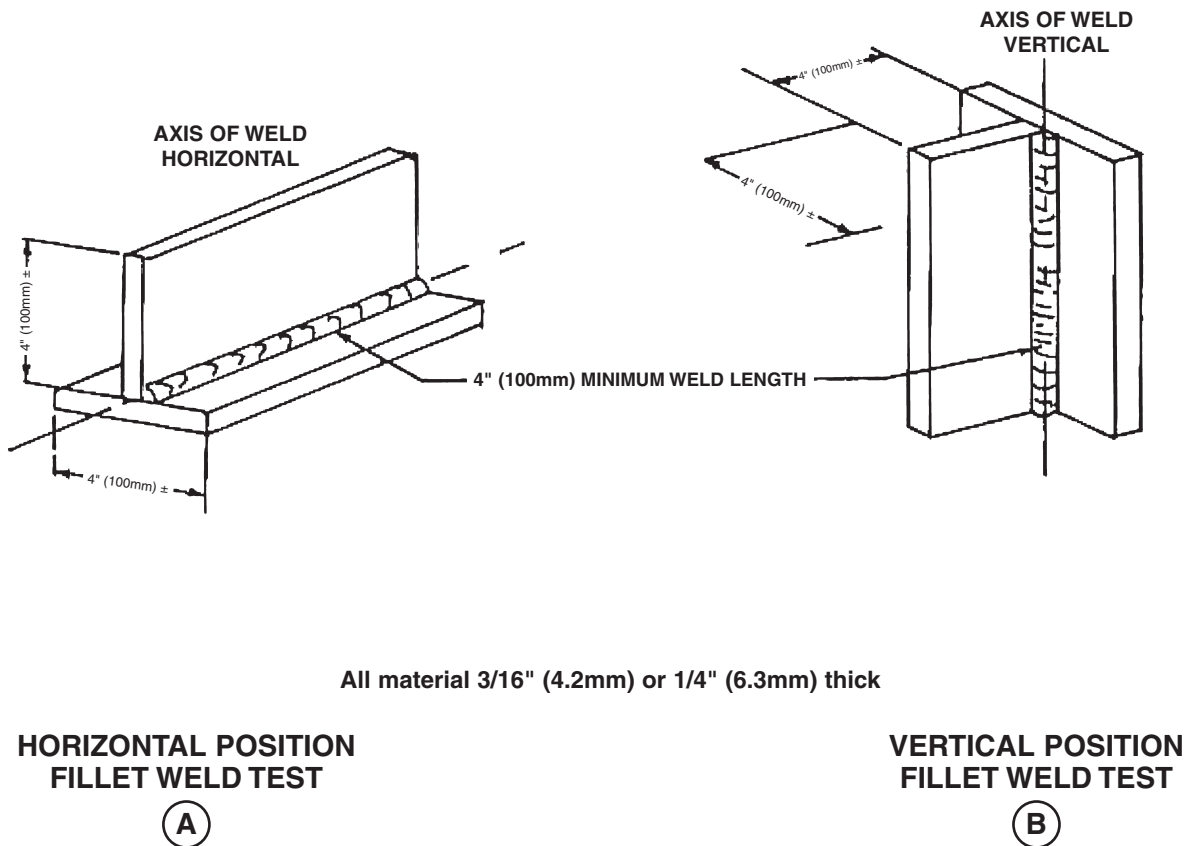

Fig. 5.8 Test Positions

5.9 WELDING PROCEDURE

The welding procedure shall comply in all respects with the Procedure specification.

5.10 TEST SPECIMENS — NUMBER, TYPE AND PREPARATION

Two (2) test welds shall be made for each procedure and position. For each type of test weld, one shall be made with a 3/16" (4.7 mm) fillet weld and one shall be made with a 1/8" (3.1 mm) fillet weld.

5.11 TEST RESULTS REQUIRED

5.11.1 All welds shall be visually inspected and shall be considered acceptable if the inspection shows that:

5.11.1.1 The weld has no cracks.

5.11.1.2 Thorough fusion exists between weld metal and base metal.

5.11.1.3 All craters are filled to the full cross section of the weld.

5.11.1.4 Weld profiles are in accordance with 3.6.

5.11.1.5 The frequency of piping porosity in fillet welds does not exceed one in each 4" (100 mm) of length and the maximum diameter does not exceed 3/32" (2.3 mm).

5.11.1.6 Fillet welds in any single continuous weld shall be permitted to underrun the nominal fillet size specified by 25% without correction, provided the undersize weld does not exceed 10% of the length of the weld.

5.12 RECORDS

Records of the test results shall be kept by the grating fabricator and shall be available to those authorized to examine them.

5.13 RETESTS

If any one test specimen fails to meet the test requirements and all others pass, two retests for that particular type of test specimen shall be performed with specimens cut from the same procedure qualification test material. The results of both retest specimens shall meet the test requirements.

PART III WELDER, WELDING OPERATOR AND TACKER

5.14 GENERAL

The qualification for Welders, Welding Operators, and Tackers ability to produce sound welds shall be the same as Part II Procedure Qualification.

5.15 PERIOD OF EFFECTIVENESS

The qualification of Welders, Welding Operators, and Tackers shall be considered as remaining in effect indefinitely unless (1) the person is not engaged in the given process of welding for which he is qualified for a period exceeding 6 months; or unless (2) there is some specific reason to question his ability.

PART IV QUALIFICATION FORMS

The following forms are offered as examples of Qualification Reports. Other formats maybe used if the contents cover the pertinent parts of this standard for steel, aluminum and stainless steel grating.

ORGANIZATION _____

Serial No. _____

Date _____

WELDING PROCEDURE FOR _____

Revision No. _____

Revision Date _____

1.0 Scope - This procedure is to be used only within the position and thickness limits shown on the Qualification Record, and in compliance with the referenced specifications.

2.0 Reference Specification(s)

- 2.1 _____
- 2.2 _____
- 2.3 _____
- 2.4 _____

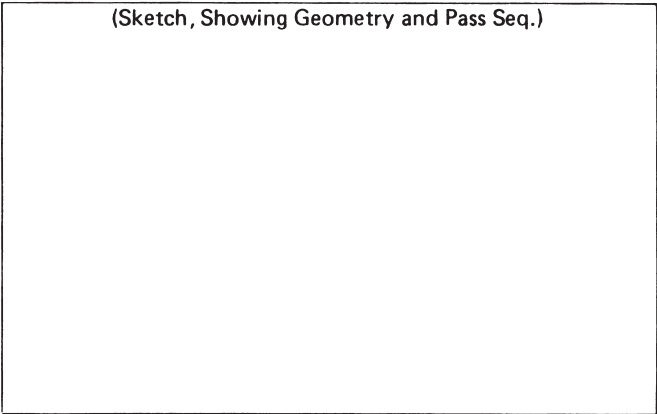

3.0 Weld Requirements

- 3.1 Type - Groove _____ Fillet _____ Other* _____
- 3.2 Size _____
- 3.3 Length _____
- 3.4 No. of Passes _____
- 3.5 No. of Layers _____
- 3.6 Position of Welding _____

4.0 Welding Process(es)

- 4.1 Manual Metal Arc _____
- 4.2 Tungsten Inert Gas _____
- 4.3 Metal Inert Gas _____
- 4.4 Other* _____

5.0 Special Conditions

- 5.1 Chill Block - as per sketch _____ None _____
- 5.2 Sequence - as per sketch _____ None _____
- 5.3 Fixture No. _____ None _____
- 5.4 Weld Appliance No. _____ None _____
- 5.5 Other* _____

6.0 Base Material(s)

- 6.1 Type _____
- 6.2 Specification _____
- 6.3 Thickness _____
- 7.0 Filler Material(s)
- 7.1 Type _____
- 7.2 Specification _____
- 7.3 Classification _____

8.0 Welding Conditions

Pass No.	Layer No.	Filler Metal		Current			TIG Cup		Electrode		Shielding Gas - Type:	
		Size	Type	Amps	Volts	Pol	Size	Type	Size	Type	Torch Flow	Purge Flow

9.0 Inspection

- 9.1 Visual _____
- 9.2 Other* _____
- _____
- _____

10.0 Heat Treatment

- 10.1 Pre-heat temperature _____ °F: _____ °C
- 10.2 Interpass temperature _____ °F: _____ °C
- 10.3 Post-heat temperature _____ °F: _____ °C
- 10.4 Time at temperature _____

Q.C. Witness _____

11.0 Qualifications

- 11.1 Procedure per tests shown in Qualification Record No. _____
- 11.2 Weldor(s) per tests shown in Qualification Record No. _____

*When "other" spaces are used, supply all pertinent information showing compliance with procedure specifications and details of essential variables.

Weldor _____ Name _____ Sig. _____ Signature _____ Cog. Engr.

Supervisor _____

ORGANIZATION _____

Qualification Record No. _____

1.0 This form, when completed, constitutes a record of qualification of Procedure No. _____

1.1 In compliance with Welding Specification No. _____.

2.0 Base Material(s)
2.1 Type of Analysis _____
2.2 Specification(s) _____
2.3 Other Reference(s) _____
2.4 Thickness _____

4.0 Shielding
4.1 Flux, Name _____ Composition _____
4.2 Inert Gas _____ Composition _____

3.0 Filler Material(s)
3.1 Type or Analysis _____
3.2 Specification(s) _____
3.3 Other Reference(s) _____
3.4 Size(s) _____

5.0 Heat Treatment
5.1 Pre-heat Temperature _____ F: _____ C
5.2 Interpass Temperature _____ F: _____ C
5.3 Post-weld Heat Treatment _____

7.0 Position(s), Welding _____

6.0 Backing _____ Yes _____ No Type _____
6.1 Backing Removed _____ Left _____

8.0 Welding conditions are certified to be strictly as shown in the referenced procedure, a true copy of which is attached hereunto.

(Signature) _____ Weld. Eng.

9.0 Qualification, Scope and Limits
9.1 Position(s) _____
9.2 Thickness Range _____
9.3 Material(s) _____
9.4 Accessibility _____

10.0 Weldor's Name _____
10.0 Symbol or No. _____
Who by virtue of these tests, meets performance qualification requirements.

It is hereby certified that the statements in this record are correct and that the test welds were prepared, welded, inspected, and tested in strict accordance with the referenced specifications.

_____ Organization _____

_____ Witness By _____
(Signature) Title

